



RARITAN

The Most Dependable Name on the Water

1700 SERIES WATER HEATER



World-renowned water heater specially designed for the marine environment. Provides the comfort and convenience of reliable hot water.

Benefits

- Simple installation – retrofits to most on-board pressure systems
- Proven long-life design
- Withstands the rigors of the marine environment
- Glass-lined steel tank is more durable than stainless steel
- Attractive polymer jacket resists corrosion from dampness
- Ignition-protected, adjustable thermostat
- Round tanks are designed to withstand more pressure than square tanks
- Glass-lined steel tank for long life and high efficiency
- Environmentally friendly CFC-free foam insulation
- Replaceable magnesium anode to protect tank and neutralize acids in the water
- The tank is covered by a five-year Limited Warranty
- Each unit is assembled by hand, individually tested and backed by Raritan's two-year Limited Warranty and legendary technical support team

Options

- Available in 6, 12 and 20 gallon models – with or without engine heat exchangers
- Available for 120V AC or 240V AC

Raritan products are chosen by powerboat, sailboat, houseboat and RV owners and manufacturers the world over for their dependability, environmental responsibility, simplicity of installation, operation and maintenance. The product line includes house-hold style toilets, marine toilets, marine sanitation devices and systems, cleaning products, icemakers, water heaters and rudder angle indicators.

To view our complete line as well as obtain installation and servicing guides: visit www.raritaneng.com

1700 SERIES WATER HEATER

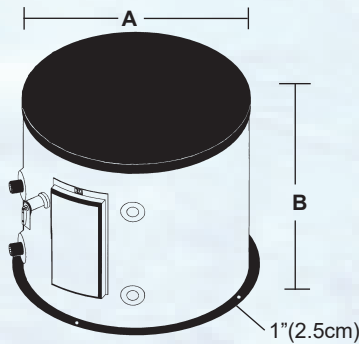

Size	A	B	Shipping Wt.
6 gal.	14 1/2"(36.9cm)	16 1/4"(41.9cm)	36lbs/16kg
12 gal.	18 3/4"(47.6cm)	16 1/4"(41.9cm)	62lbs/28kg
20 gal.	18 3/4"(47.6cm)	24 1/4"(60.6cm)	81lbs/37kg

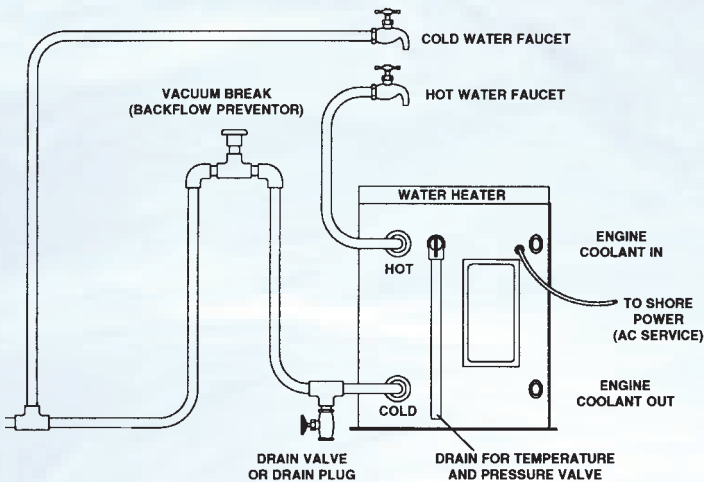

The "1700 Series" water heater provides hot water for galley and shower. Dense foam insulation provides better and longer heat retention than traditional fiberglass. The tank itself is protected by a 75 PSI T & P (temperature and pressure) relief valve. The cylindrical design of the tank enables it to withstand more pressure than a cube shaped tank.

Heat exchanger models can be connected to the engine cooling system. This provides the added convenience of hot water when underway or generator power is not available. The innovative heat exchanger is over seven feet in length and is evenly coiled throughout the interior of the tank, providing hot water rapidly and efficiently.

Raritan's water heaters use an ignition protected thermostat. Although it is factory set to 120°F, it is adjustable from 110° to 160°F and has a safety shut down limit of 190°F. All models and sizes have the plumbing connections on the same side to simplify installation. Hot and cold water connections are 3/4" male NPT (National Pipe Thread). Heat exchanger connections are 3/4" female NPT.

Choose from options below to create a part number.

Sample part# 170601 - 1700 Series Water Heater, 6 gallons, without heat exchanger, 120V AC

17	Water Heater	06	six gallon	0	without heat exchanger	1	120V AC	01	GAZ heat exchanger fittings
		12	twelve gallon	1	with heat exchanger	2	220V AC	02	METRIC heat exchanger fittings
		20	twenty gallon					03	4500 W heating element 240VAC only



For more information contact:
 Raritan Engineering Company Inc.
 530 Orange Street
 Millville, NJ 08332, USA
 Telephone: 856-825-4900
 Toll Free: 1-800-352-5630
 Fax: 856-825-4409
 e-mail: info@raritaneng.com