


✧ FLUSH CONTROL

Installation, Operation and Maintenance Instructions

Part# STCBL

THE FOLLOWING ARE CAUTIONARY STATEMENTS THAT MUST BE READ AND FOLLOWED DURING BOTH INSTALLATION AND OPERATION.

WARNING:  Raritan Engineering Company, Inc. recommends that a qualified person or electrician install this product. Equipment damage, injury to personnel or death could result from improper installation. Raritan Engineering Company, Inc. accepts no responsibility or liability for damage to equipment, injury or death to personnel that may result from improper installation or operation of this product.

WARNING: HAZARD OF SHOCK OR FIRE

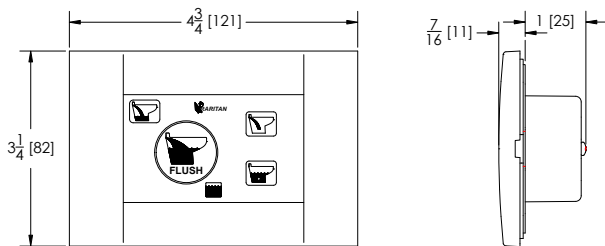


Always use recommended fuse, circuit breaker and wire size.

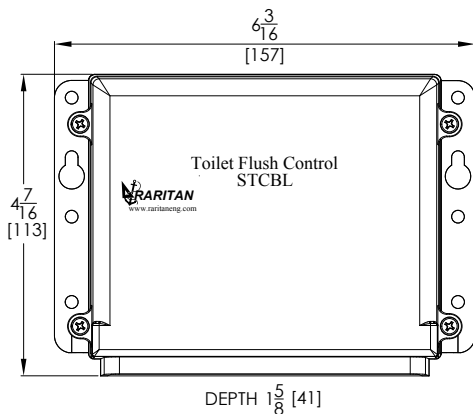
Motors used with this product are “Ignition Protected”. They are not however, explosion-proof as defined in 46CFR 110.15-65(e), Subchapter J-Electrical Engineering.

DO NOT run continuously for more than 30 seconds.

Panel





Control box





Description:


✧ Flush Control is a controller for flushing toilet to optimize water use without compromising the quality of flush.

Control consists of a controller and panel (batteries included).

✧ Flush Control is designed to start a flushing cycle if **NORMAL FLUSH**  or **WATER SAVER**  buttons are pressed.

WATER ONLY  button brings inlet water to the bowl when pressed and **EMPTY ONLY**  button evacuates the bowl.

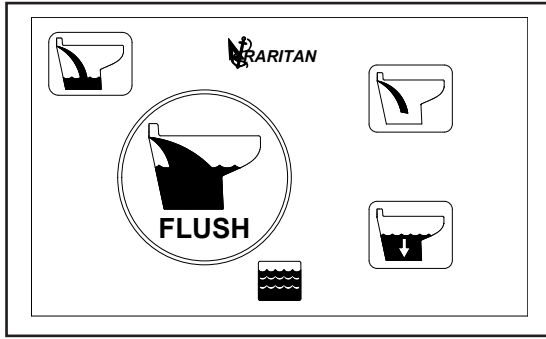
Flush timing is preset from the factory for Sequential Flushing. Flush settings can be changed by downloading the Raritan App to your Smartphone. See “Changing Flush Settings Instructions” on page 8.

✧ Flush Control has a Holding Tank Full  indicator. Optional Holding Tank Full Sensors are sold separately. Part # STCTSA (see page 7).

✧ Flush Control is reverse polarity protected. In case of reverse polarity motors and solenoid will activate as soon as power is connected. After reverse polarity is corrected (within 10 minutes), unit will work as normal.

Programming is not required. This panel has been factory paired with the included control board.

NOTE!! Wall panel becomes inoperable when control board is connected to the APP. Wall panel will automatically reconnect once APP is disconnected.



✧ FLUSH CONTROL PANEL

1. NORMAL FLUSH

Press to start timed flushing cycle. There are three cycles of inlet and discharge. First cycle removes most of the waste. Second cycle removes remaining waste if any left after first cycle. Third cycle clears all discharge housing and lines with clean water. Last fill is to retain water in the bowl for next use.


2. WATER SAVER

Press to start water saver cycle. This cycle has only one cycle of inlet and discharge to clear liquid waste. Last fill is to retain water in the bowl for next use.

3. EMPTY ONLY

Press to evacuate the bowl. Discharge pump runs as long as this button is held.



4. WATER ONLY

Press to add water in the bowl. Inlet water solenoid/pump runs as long as button is pressed with an eight second limit. After limit is reached, this button is disabled to prevent overflow of the bowl. To enable again, EMPTY ONLY  button must be pressed.

5. HOLDING TANK FULL

This will occur when NORMAL  or WATER SAVER  buttons are pressed.

These buttons will also be disabled. The indicator will blink and beep for 5 seconds.

The EMPTY ONLY  and WATER ONLY  will work. Optional Holding Tank Sensor must be installed.





LOW FLUSH CONTROL PANEL BATTERIES

Holding Tank Full Indicator will blink for 30 seconds when the Flush Control Panel's batteries need to be replaced. See page 3, FIG 2 for batteries location. 3 AAA batteries required.

Download the free Raritan App to change flush modes or timings. The App can also be used to test flush settings, diagnose problems, device information and update firmware.

The Raritan ✧ Flush Control offers two different flush modes to choose from:

Sequential Flush: In this mode, the toilet will add water and discharge waste separately. This fill/empty cycle will repeat once in WATER SAVER  and three times during the NORMAL FLUSH  cycle. At the end of this sequence cycle, a short pause will be followed by a final fill to leave water remaining in the bowl.

This mode is designed to provide the most efficient flush possible while using the least amount of water. It keeps the discharge pump flooded while providing powerful suction to remove waste from the bowl.

NOTE: All toilets as shipped from factory are set to the Sequential mode.

Continuous Flush: In this mode, the toilet will add water to wet the bowl first and then follow with the inlet and discharge motors flushing together for the remainder of the cycle. At the end of this continuous cycle, a short pause will be followed by a final fill to leave water in the bowl.

This mode may be more suitable for installations in which a continuous flow of water is desired and water use is not as great a concern.

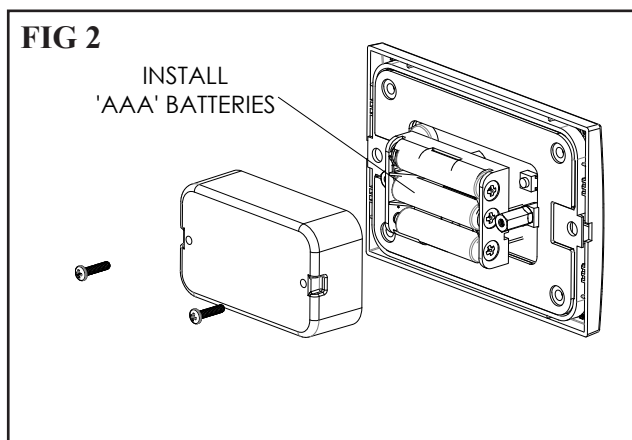
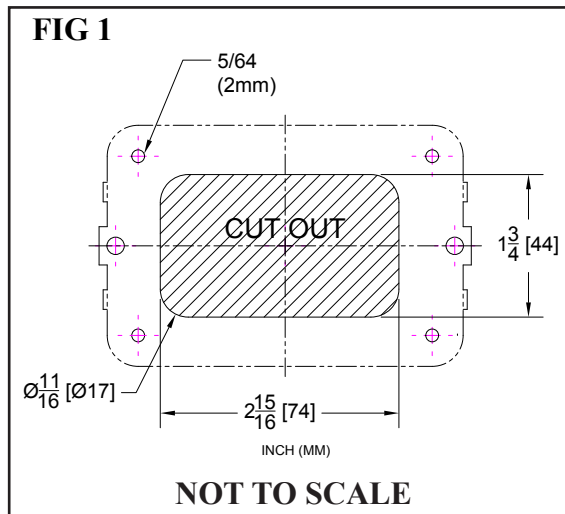
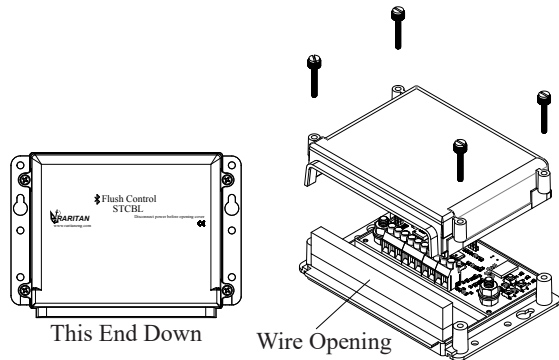
For changing Flush Mode and Timing see 'Changing Flush Settings' section on page 8.

Installing the Flush Control Panel

1. Cut out cross-hatched area per FIG 1. Mark mounting holes using wall plate as guide.
2. Remove cover and install three AAA batteries (included). See FIG 2.
3. Secure control using mounting screws.

✧ Installing the Flush Control Box

1. Locate box near toilet in a dry and accessible area.
2. Using two screws, fasten the control to wall with wire opening at the bottom.
3. Open cover to access wiring connector.
4. Choose one of the wiring diagrams (FIG 3, 4, 5, 6 or 7) to route all wires.
5. Replace cover.



Recommended Wire and Fuse/Circuit Breaker Sizes

ATLANTES FREEDOM VORTEX VAC AND MARINE ELEGANCE

Table 1-Sea Water Model

(sizes based on both remote intake and discharge pumps amp added together)

Units Voltage	Circuit Breaker/fuse size (amps)	Toilet Discharge Pump Amp draw	Remote Intake Pump Amp draw	10 feet	15 feet	20 feet	30 feet	40 feet	50 feet
12 VDC	30	18	10	10 AWG	8 AWG	6 AWG	4 AWG	4 AWG	2 AWG
24 VDC	20	10	5	16 AWG	14 AWG	12 AWG	10 AWG	10 AWG	8 AWG

Table 2- Pressurized Freshwater Model

Units Voltage	Circuit Breaker/fuse size (amps)	Amp draw	10 feet	15 feet	20 feet	30 feet	40 feet	50 feet
12 VDC	25	18	10 AWG	10 AWG	8 AWG	6 AWG	6 AWG	4 AWG
24 VDC	15	10	16 AWG	16 AWG	14 AWG	12 AWG	10 AWG	10 AWG

SEAERA QC MODEL 162

Table 3- Sea Water Model

(sizes based on both remote intake and discharge pumps amp added together)

Units Voltage	Circuit Breaker/fuse size (amps)	Toilet Discharge Pump Amp draw	Remote Intake Pump Amp draw	10 feet	15 feet	20 feet	30 feet	40 feet	50 feet
12 VDC	25	13	10	10 AWG	8 AWG	6 AWG	6 AWG	4 AWG	4 AWG
24VDC	15	7.5	5	16 AWG	14 AWG	12 AWG	10 AWG	10 AWG	8 AWG

Table 4- Pressurized Freshwater Model

Units Voltage	Circuit Breaker/fuse size (amps)	Amp draw	10 feet	15 feet	20 feet	30 feet	40 feet	50 feet
12 VDC	25	13	12 AWG	10 AWG	10 AWG	8 AWG	6 AWG	6 AWG
24 VDC	15	7.5	16 AWG	16 AWG	14 AWG	12 AWG	10 AWG	10 AWG

Table 5 - Remote Intake Pump Only (Seawater and Seafresh Models)

Units Voltage	Circuit Breaker/fuse size (amps)	Amp draw	10 feet	15 feet	20 feet	30 feet	40 feet	50 feet
12 VDC	15	10	14 AWG	12 AWG	10 AWG	10 AWG	8 AWG	6 AWG
24 VDC	10	5	16 AWG	16 AWG	16 AWG	16 AWG	14 AWG	12 AWG

NOTES: for Wiring

- Distances are from source to unit and back to source.
- Distance from power source to remote intake pump **MUST** be included when determining total distance.
- Recommended conductor wire minimum AWG (mm²) for 3% voltage drop.
- Recommended conductor sizes are based on 105°C rated insulation. Single conductor (not bundled), refer to ABYC Standards for sizes with other insulation ratings.
- For 120/240 VAC units, use 12VDC specifications from transformer to unit. See transformer instructions for further wiring details.

WIRING

WARNING: Hazard of Shock and Fire

- Always use proper wire, wire connectors and fuse/circuit breaker. See Specification Chart.
- Secure wire properly.
- Do not connect appliances to toilet circuit.
- Make sure power is off before proceeding.
- Use proper wire terminals for all wire connections.

- Determine proper wire size by measuring distance from:
 - Power Source to control box and back to power source.
 - Remote pump units determine proper wire size for remote pump from wiring diagram.
- Select proper wire and fuse/circuit breaker size from Specifications on Table 1.
- Install fuse/circuit breaker in positive line at source.
- Wire control to the toilet and battery using one of the following wiring diagrams.

CONVERSIONS

Wire - AWG to mm

AWG	16	14	12	10	8	6	4	2
mm	1.5	2.5	4.0	6.0	10.0	16.0	25.0	35.0

Feet to Meters

Feet	10	15	20	25	30	40	50
Meter	3.1	4.6	6.1	7.6	9.2	12.2	15.2

MSD OPERATION

- To start Electroscan or Purasan EX from Smart Toilet Control (STC), wire per Fig 6.
 - To start/flush toilet by activating the Electroscan or Purasan EX, wire per Fig 7.
- For Lectra/San MC, EC or Purasan call Raritan Customer Service

FIG 3

WIRING FOR FLUSH CONTROL PRESSURIZED FRESHWATER MODELS

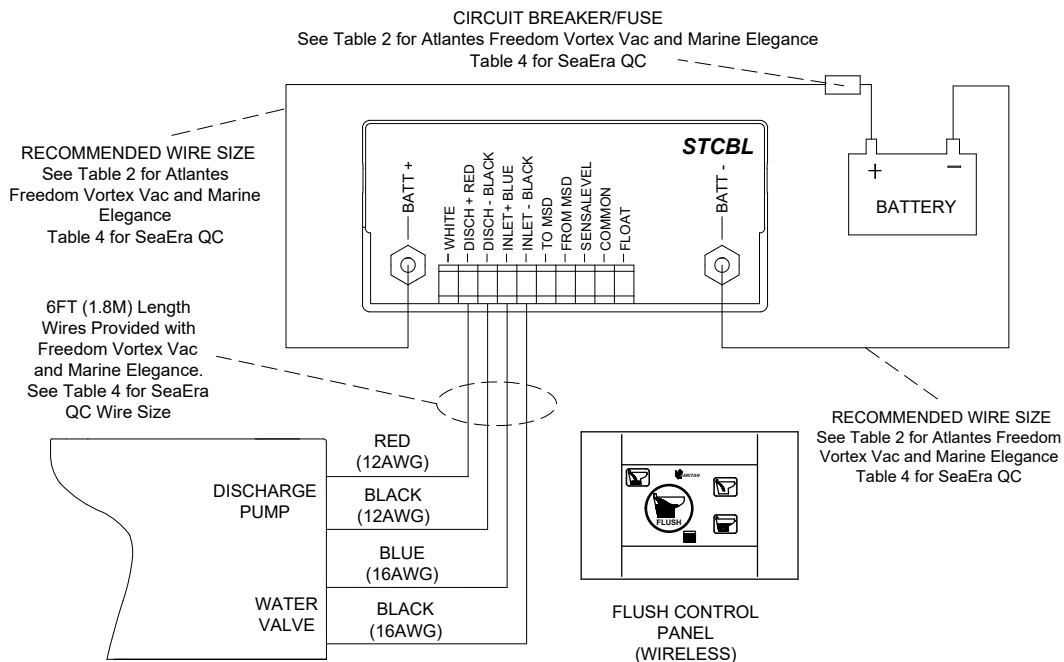


FIG 4 WIRING FOR FLUSH CONTROL, REMOTE PUMP MODELS

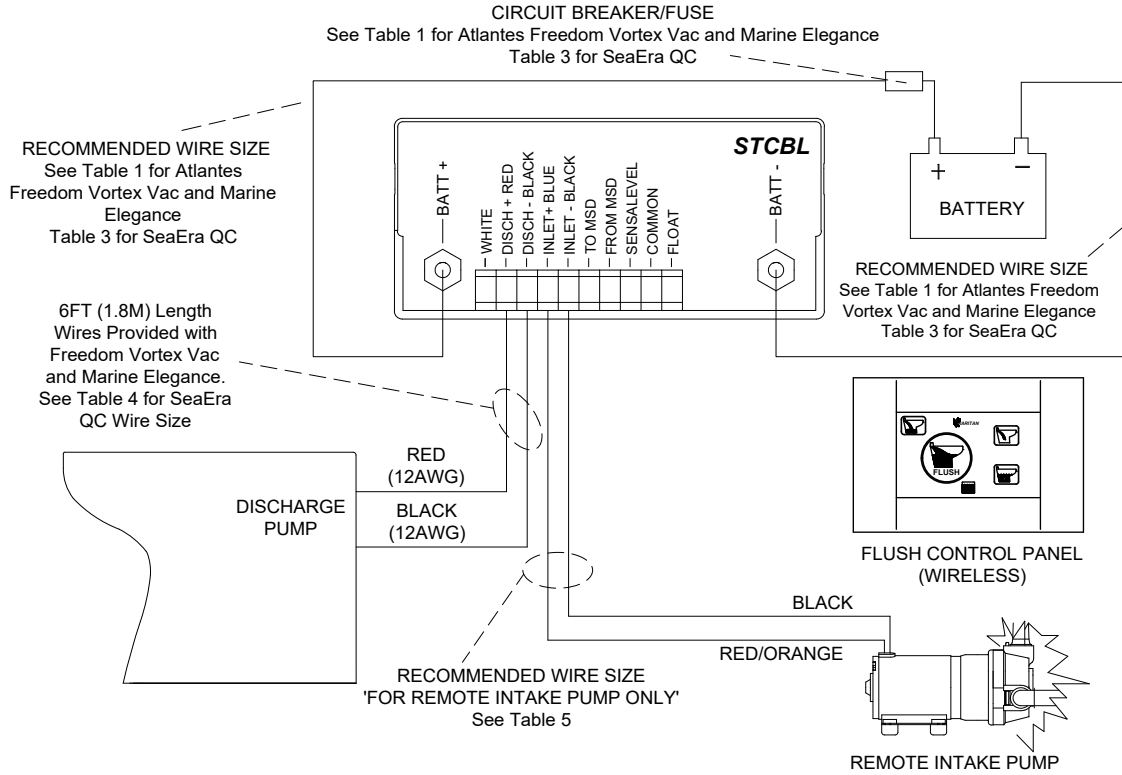
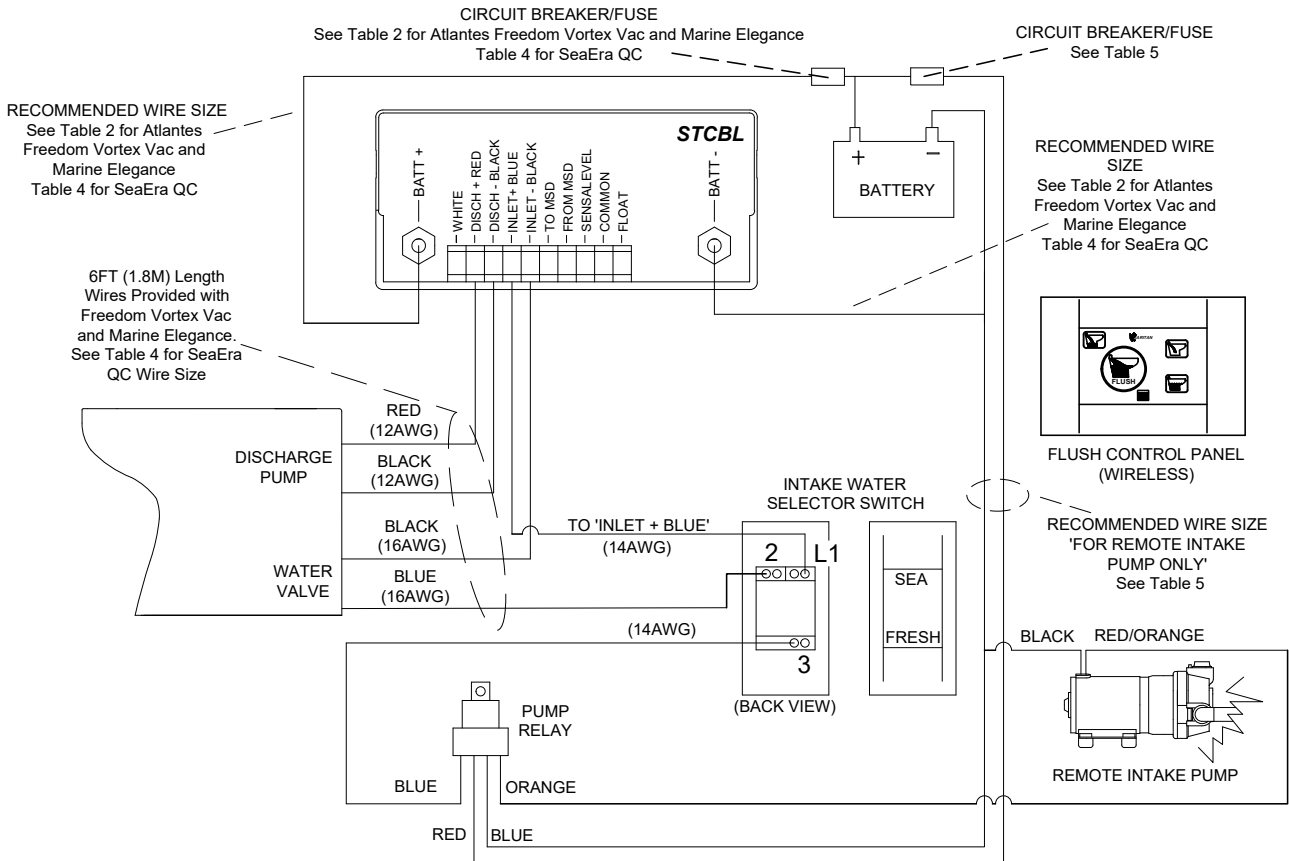
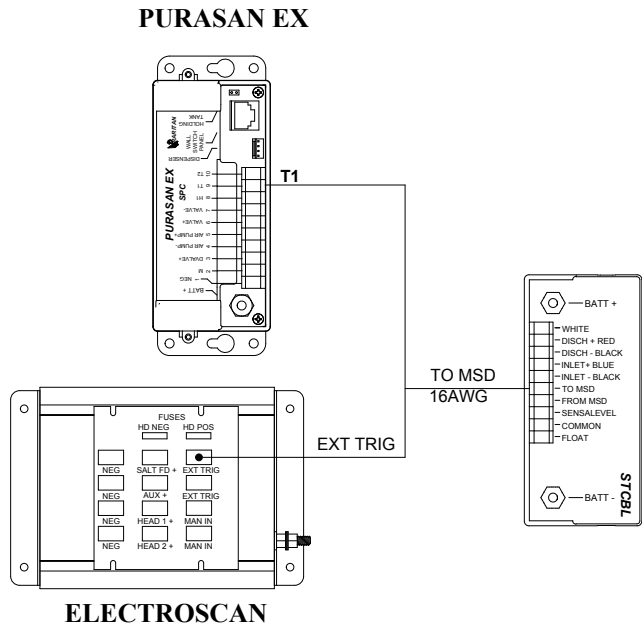


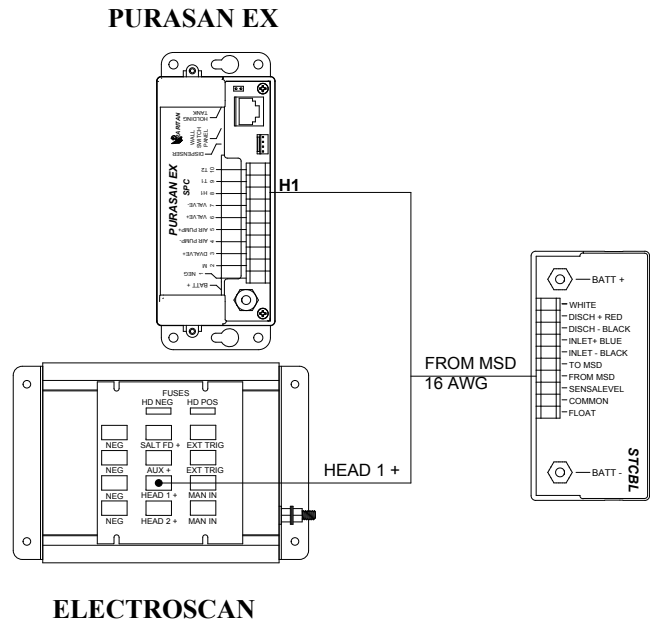
FIG 5 WIRING FOR FLUSH CONTROL, SEA/FRESH MODELS



**FIG 6
WIRING FOR FLUSH CONTROL WITH MSD**

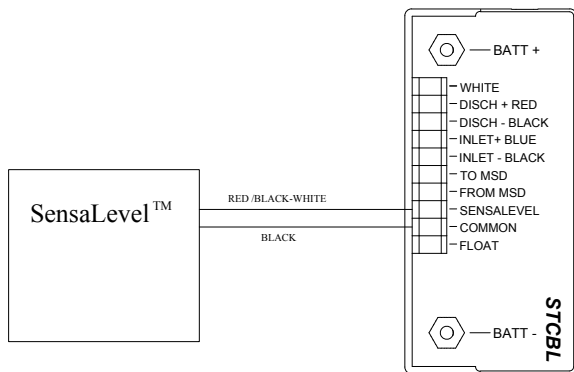


**FIG 7
WIRING FOR FLUSH CONTROL WITH MSD**

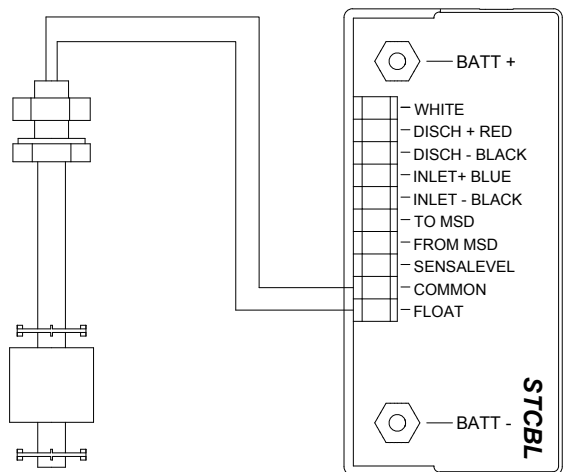


OPTIONAL HOLDING TANK INDICATORS AVAILABLE

**FIG 8
RARITAN PART# STCTSA
HOLDING TANK FULL INDICATOR**



**FIG 9
RARITAN PART# STCFL
HOLDING TANK FULL INDICATOR**



Factory settings will work for most installations without making any changes to timing. To make changes to timing, follow guidelines below to optimize flushing after installation.

Observation / Issue	Action
Water does not empty all the way in the first cycle	Increase discharge timing (Flush Empty Time 1 or 2)
Water empties, but discharge pump runs more than a second after all water is gone in first cycle	Decrease discharge time (Flush Empty Time 1 and 2)
Solids and toilet paper remain in the bowl after first cycle	Increase (Pre Flush Time)
Water level too high after initial fill cycle	Reduce water retention time (T3)
There is little or no water left in the bowl	Increase water retention time
Water siphons out after 10 or 15 minutes from the bowl	Enable longer pause before retention fill

CHANGING FLUSH SETTINGS

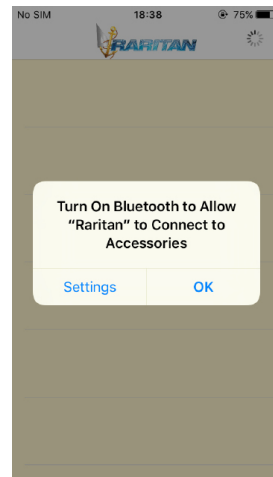
Flush settings are factory programmed to provide optimal flushing for most installations. Some installation may require adjustments to the settings. For complete instructions regarding the App, go to www.raritaneng.com.

3. Turn power on to Flush Control.
4. Open the Raritan App on Smart Phone. Press OK.

1. Download the Raritan App to your smart phone. (Available in iOS and Android phones)

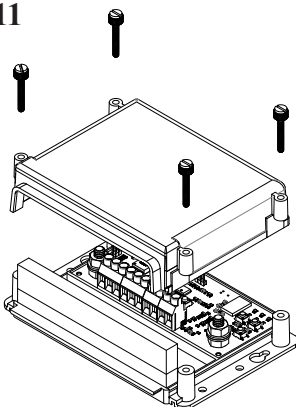
FIG 12

FIG 10



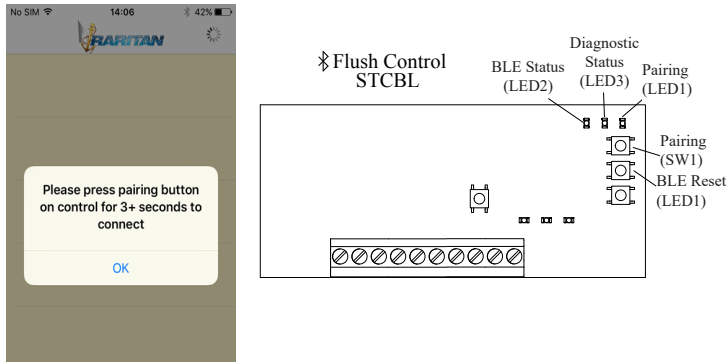
2. Remove cover from the flush control.

FIG 11



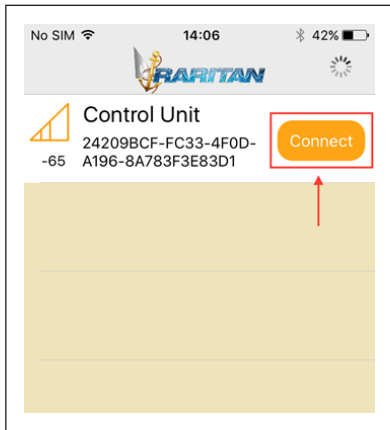
5. Press and hold Pairing Switch (SW1) on Flush Control for 3 seconds then release. After 3 seconds, Diagnostic Status (LED3) will flash one time quickly. The pairing (LED1) and the BLE Status (LED2) will flash together 1 flash per second.

FIG 13



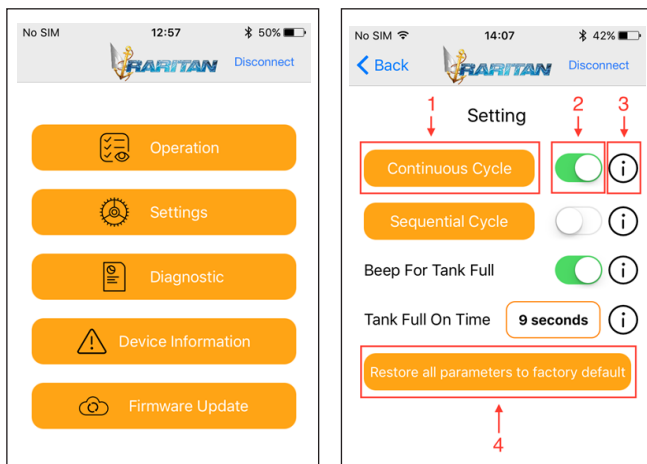
6. On Smartphone press 'Connect'.

FIG 14



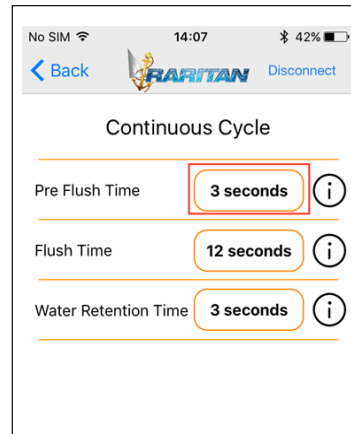
7. Press 'Setting'. This screen allows users to select between Continuous or Sequential Flush cycles. Pressing (i) will provide further detail to each function. It can also be used to restore to factory settings.

FIG 15



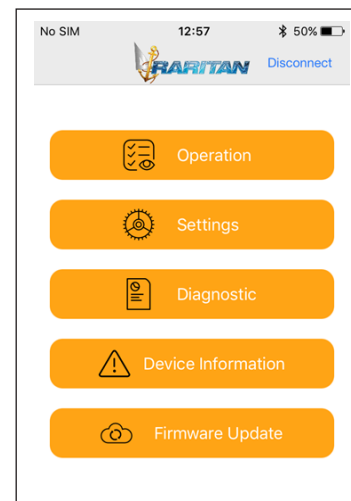
8. Pressing Continuous or Sequential Cycle allows for detailed timing adjustments.

FIG 16



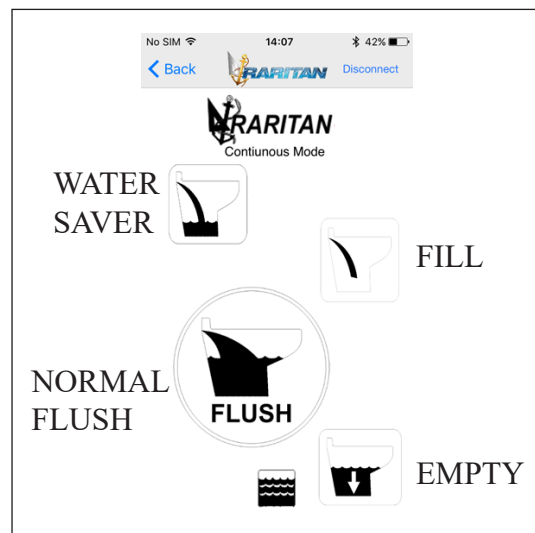
9. Press the back button and select Operation.

FIG 17



10. Test new settings by pressing symbols below.

FIG 18



11. Select Disconnect to resume use of wireless wall panel.

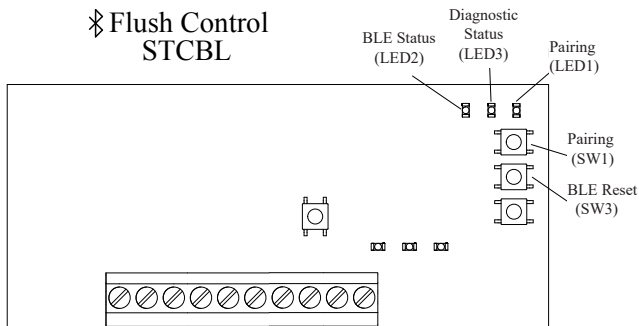
PAIRING NEW PANEL OR CONTROL

When replacing a new Panel with an existing Control (or New Control with Existing Panel), the units **must** be paired together.

IMPORTANT: Power to control **MUST BE ON** and batteries installed in wall panel.

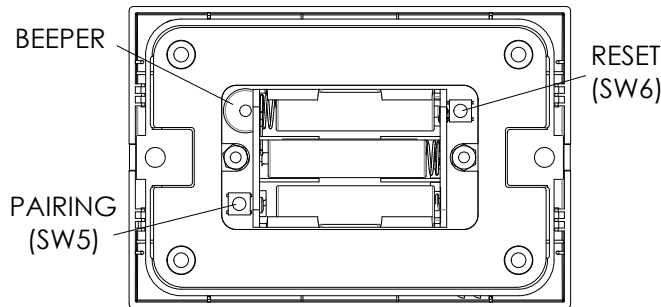
1. Press and hold Pairing Switch (SW1) on Flush Control for 10 seconds then release. All LEDs (1, 2 & 3) should be OFF.

FIG 19



2. Press and hold Pairing Switch SW5 on the Wall Panel for at least 7 seconds. All LEDs on the Control (1, 2 & 3) will still be off.

FIG 20



WALL PANEL

3. Press for 1 second and release SW1.
4. Press for 1 second and release SW5.
5. You will see that the LED2 will be on for several seconds then LEDs1 and 2 will begin to flash together 1 blink/2 seconds.
6. The Panel and Control are now paired.

NOTE: If Diagnostic Status (LED3) remains blinking (1 blink/sec), press BLE Reset (SW3) to turn off LED3.

TESTING CONTROL

The Control can be tested independently (as well as connected to toilet).

Press FROM MSD switch.

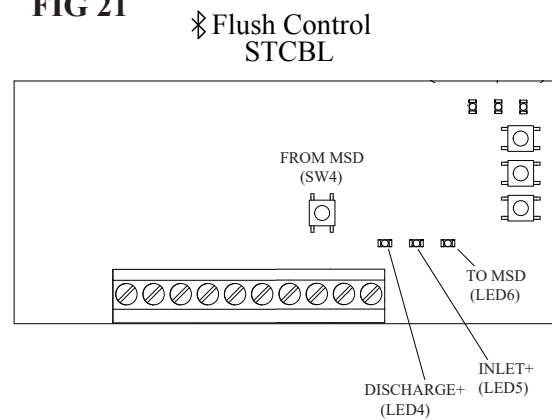
Inlet and Discharge LEDs flash on and off indicating their respective pumps.

TO MSD LED light will flash on for one second at beginning of flush cycle.

Flush cycle will either be sequential or continuous depending on the setting.

Factory setting is sequential.

FIG 21

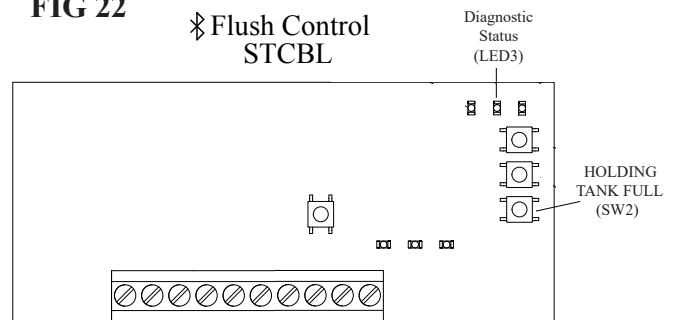


TESTING HOLDING TANK FULL CIRCUIT ON CONTROL

Press Holding Tank Full switch (SW2)

Diagnostic LED must go on.

FIG 22

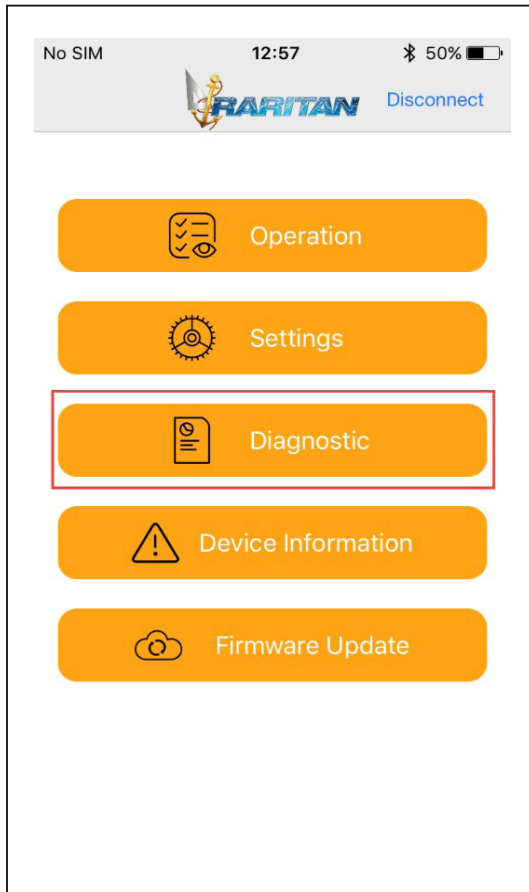


OPERATING DIAGNOSTICS SCREEN

Diagnostics Screen can be helpful in determining the cause of a problem. It is also useful for evaluating the performance of pumps.

The Diagnostic button is located on the main screen. (See below)

FIG 23



The Diagnostics will record up to 250 consecutive cycles. The data it records are:

Inlet Amps

Dischrge Amps

Inlet Motor ON/OFF

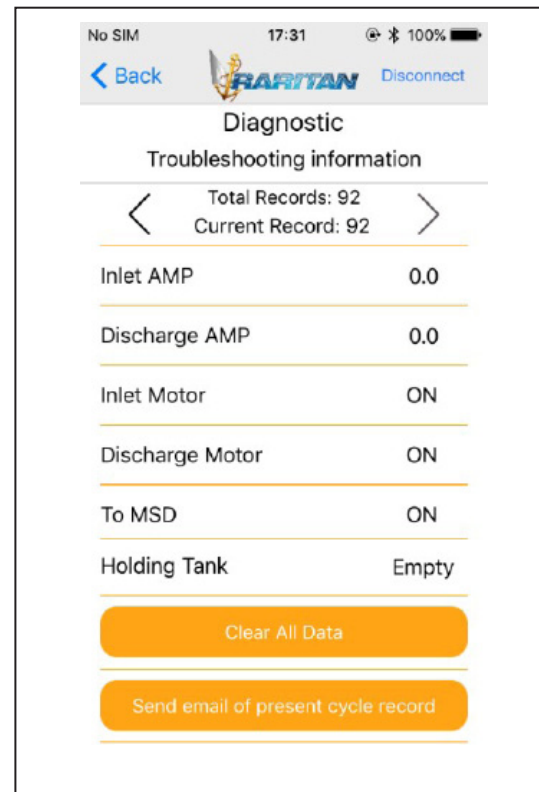
Discharge Motor ON/OFF

“TO MSD” ON/OFF

Holding Tank Empty/Full.

Use the < and > to scroll thru the records.

FIG 24



DIAGNOSTIC (SMARTPHONE) TROUBLE SHOOTING

(SEE FIG 24)

Problem	Inlet Amps	Discharge Amps	Inlet On/Off	Discharge On/Off	To MSD On/Off	Holding Tank Full/Empty	Corrective Action
No inlet water	0.3 (or less)	>2	ON	ON	N/A	N/A	Open circuit to inlet. Check wiring or inlet pump/valve. Correct wiring or replace defective pump/valve.
No inlet water	0.3 (or less)	>2	OFF	ON	N/A	N/A	Short in wiring, pump/valve or defective control. Disconnect wiring for pump/valve from control. Run water saver flush and check cycle results. If inlet On/Off is still off; Defective control. Replace control. If inlet On/Off is on; Defective wiring or pump/valve. Correct wiring or replace pump/valve.
No discharge	>.05	0.3 (or less)	ON	ON	N/A	N/A	Open circuit to discharge pump. Check wiring or discharge pump. Correct wiring or replace defective pump.
No discharge	>.05	0.3 (or less)	ON	OFF	N/A	N/A	Short in wiring, discharge pump or defective control. Disconnect wiring for discharge pump from control. Run water saver flush and check cycle results. If discharge On/Off is still off; Defective control. Replace Control. If discharge On/Off is on; Defective wiring or discharge pump. Correct wiring or replace discharge pump.
MSD does not activate	N/A	N/A	N/A	N/A	ON	N/A	Open circuit to MSD. Check wiring or MSD. Correct wiring or repair MSD.
MSD does not activate	N/A	N/A	N/A	N/A	OFF	N/A	Short in wiring, defective MSD or defective control. Disconnect wiring to MSD from control. Run water saver flush and check cycle results. If to MSD On/Off is still off; Defective control. Replace control. If to MSD On/Off is on; Defective wiring or MSD control. Correct wiring or replace MSD control.
Holding tank full indication, Tank Empty	N/A	N/A	N/A	N/A	N/A	FULL	Disconnect Level Sensor from control. Go to Operation and Flush Toilet (Flush or Water Saver). Toilet flushes; Defective Level Sensor or wiring. Toilet does not flush; Defective control. Replace control.
Holding tank empty indication, Tank Full	N/A	N/A	N/A	N/A	N/A	EMPTY	On control, press Holding Tank Full Switch (SW2). Diagnostic LED goes on; Defective level sensor. Check wiring or replace level sensor. Diagnostic LED does not go on; Defective control. Replace control.

FOR LIMITED WARRANTY TERMS AND CONDITION PLEASE REFER TO TOILET MANUAL

	530 Orange Street, Millville, NJ 08332 USA Telephone: 856-825-4900 FAX: 856-825-4409 www.raritaneng.com
---	--